

Lubricate all seals with clean hydraulic fluid, prior to assembly.
Do not use silicone based lubricants.

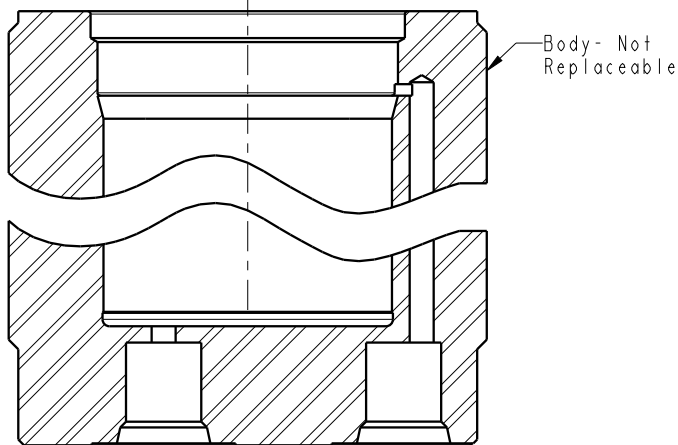
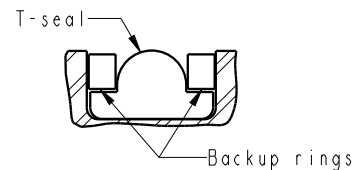
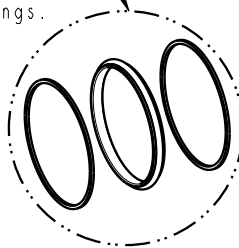
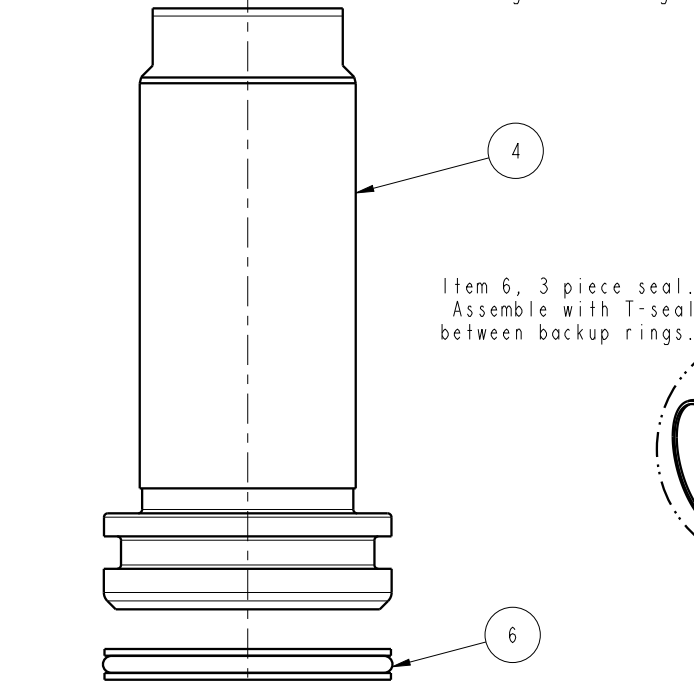
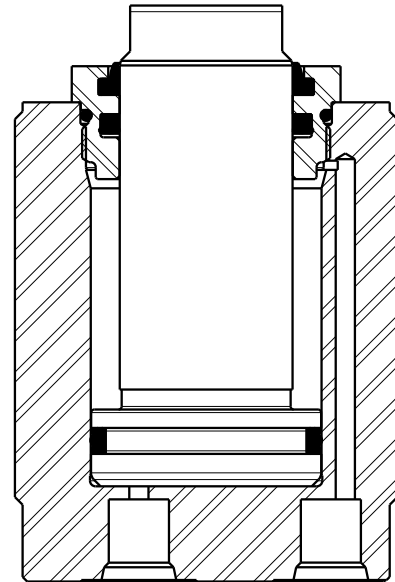
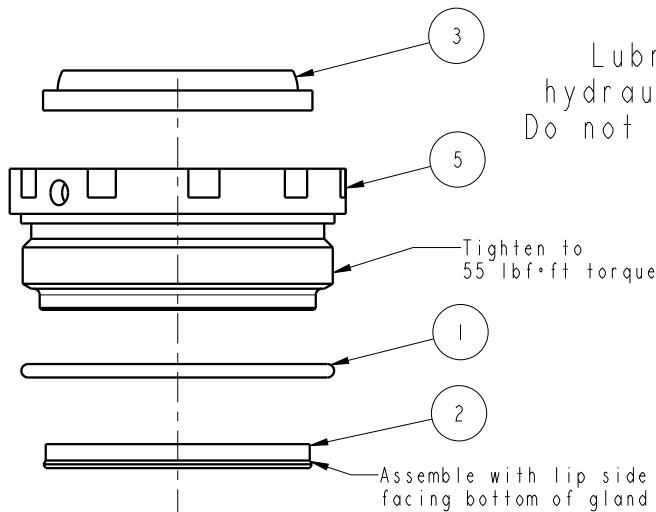

Standard Seal Kit	Fluorocarbon Seal Kit
60-2002-15	6V-2002-14
39-H110-31	39-H110-31
39-0110-48	39-0120-07
39-0010-13	39-0120-14
39-0500-20	39-0500-20

No.	QTY	PART No.	DESCRIPTION
6	1	39H11031	SEAL, T, (1 5/16X5/32X1 1/2)
5	1	82031501	GLAND, CYL, 8800 & 39.9 KN
4	1	82011507	PISTON, CYL, 8800, 1.5 STRK
3	1	39050020	WIPER, SNAP-IN, (1-1/8)
2	1	39011048	SEAL, LL, (1-1/8 X 1/8 X 1/8 X 1-3/8)
1	1	39001013	O-RING, (-029)

PARTS LIST



VEKTEK, INC.
1334 E. SIXTH AVE. P.O. BOX 625
EMPORIA, KS. 66801 U.S.A.

Model Number
20-0215-04
20-0215-04F

ASSY, CYL, TB, 8800, 1.5 STRK, DA

SIZE
A
PL2127
REV
G

FORM FEG035_PL_ASIZE, REV. B

G	5499	RELEASE	NPETERS	9/23/24
REV	IN ACCORDANCE WITH ECN	EFFECTIVE DATE	REVISED BY	DATE
DRW BY:	JACOB	DRAWING STATUS: Released		
DATE:	9/20/96	PRODUCTION APPROVED FOR RELEASED STATUS ONLY		

SHEET 1 OF 1